

PROFIBUS® PA/FOUNDATION™ FIELDBUS TRANSMITTER



- PROFIBUS® PA ver. 3.0
- FOUNDATION™ Fieldbus ver. ITK 4.6
- Automatic switch between protocols
- Basic or LAS capability with F.F.
- DIN form B sensor head mounting

Application:

- Linearised temperature measurement with RTD or TC sensor.
- Difference, average or redundancy temperature measurement with RTD or TC sensor.
- Linear resistance, potentiometer and bipolar mV measurement.

Technical characteristics:

- Bus transmitter with both PROFIBUS® PA and FOUNDATION™ Fieldbus communication.
- A unique switch function ensures automatic shift between the two protocols.
- Set-up for PROFIBUS® PA can be done via Siemens Simatic® PDM®, ABB Melody / Harmony and Metso DNA software and for FOUNDATION™ Fieldbus via Emerson DeltaV, Yokogawa CS 1000 / CS 3000, ABB Melody / Harmony and Honeywell Experion software.
- The simulation mode function can be activated by way of a magnet.
- Polarity-independent bus connection.
- 24 bit A/D converter ensures high resolution.
- PROFIBUS® PA function blocks: 2 analogue.
- FOUNDATION™ Fieldbus function blocks: 2 analogue and 1 PID.
- FOUNDATION™ Fieldbus capability: Basic or LAS.

Mounting / installation:

- For DIN form B sensor head or DIN rail mounting with the PR fitting type 8421.

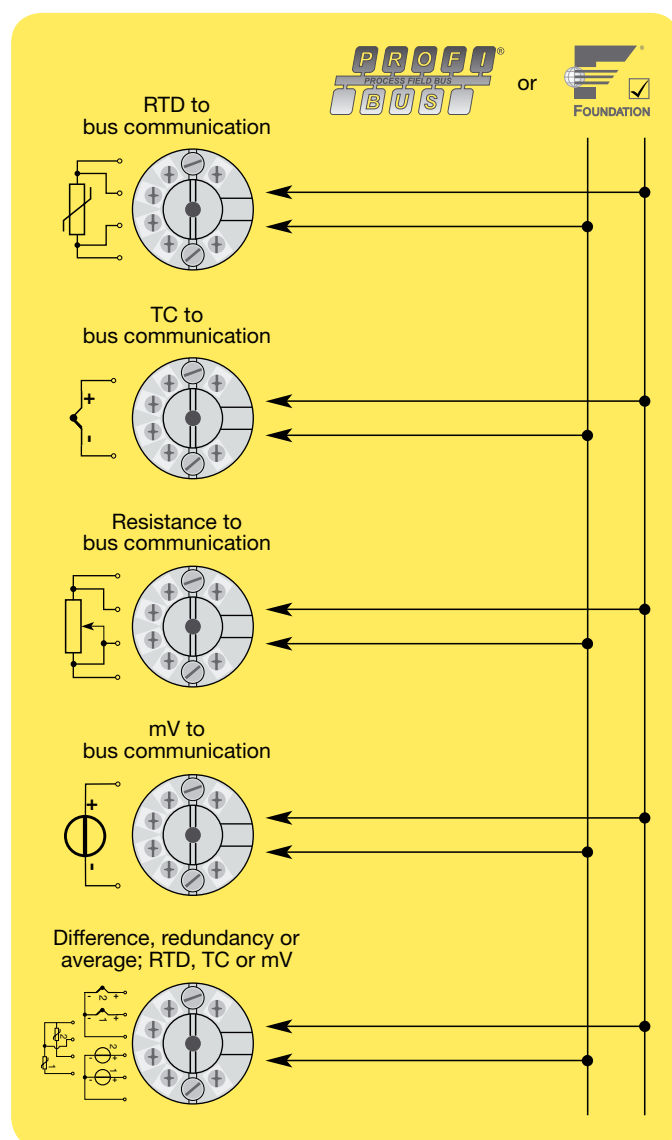

Type
5350A

***NB!** Please remember to order PR sim pin type 8422 if the simulation mode function is to be used.

Connections:

All connection options are shown in the user manual.

Connections with two sensors can be configured for 2 measurements, difference, average or redundancy.

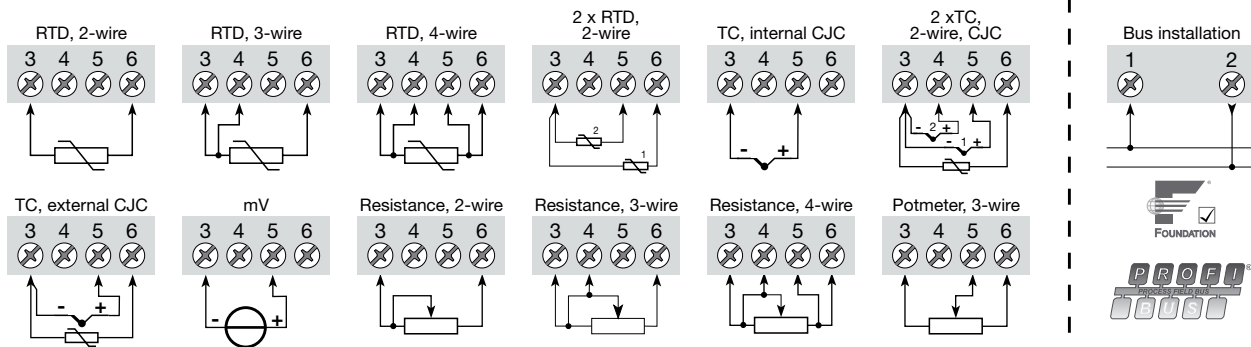

Electrical specifications:

Specifications range:

-40°C to +85°C

Common specifications:

- Supply voltage..... 9...32 VDC
- Consumption..... < 11 mA
- Isolation voltage, test / operation..... 1.5 kVAC / 50 VAC
- Signal / noise ratio..... Min. 60 dB
- Response time (programmable)..... 1...60 s
- Updating time..... < 400 ms
- Execution time, analogue input..... < 50 ms
- Signal dynamics, input..... 24 bit
- Calibration temperature..... 20...28°C
- Accuracy, the greater of general and basic values:

General values		
Input type	Absolute accuracy	Temperature coefficient
All	≤ ±0.05% of reading	≤ ±0.002% of reading / °C

Basic values		
Input type	Basic accuracy	Temperature coefficient
Pt100 and Pt1000	≤ ±0.1°C	≤ ±0.002°C / °C
Ni100	≤ ±0.15°C	≤ ±0.002°C / °C
Cu10	≤ ±1.3°C	≤ ±0.02°C / °C
Lin. R	≤ ±0.05 Ω	≤ ±0.002 Ω / °C
Volt	≤ ±10 μV	≤ ±0.2 μV / °C
TC type: E, J, K, L, N, T, U	≤ ±0.5°C	≤ ±0.010°C / °C
TC type: B, R, S, W3, W5	≤ ±1°C	≤ ±0.025°C / °C

EMC immunity influence	< ±0.1% of reading
Extended EMC immunity: NAMUR NE 21, A criterion, burst.....	< ±1% of reading

- Vibration (DIN class B)..... IEC 60068-2-6 and IEC 60068-2-64
4 g / 2...100 Hz
- Humidity..... < 95% RH (non-cond.)
- Dimensions..... Ø 44 x 20.2 mm
- Protection degree (encl. / terminal) ... IP68 / IP00
- Weight..... 55 g

Electrical specifications, input:

RTD and linear resistance input:

RTD type	Min. value	Max. value	Standard
Pt25...Pt1000	-200°C	+850°C	IEC60751/JIS C 1604
Ni25...Ni1000	-60°C	+250°C	DIN 43760
Cu10...Cu1000	-50°C	+200°C	α = 0.00427
Lin. resistance	0 Ω	10 kΩ	-
Potentiometer	0 Ω	100 kΩ	-

- Cable resistance per wire..... 50 Ω
- Sensor current..... Nom. 0,2 mA
- Effect of sensor cable resistance (3- / 4-wire)..... < 0.002 Ω/Ω
- Sensor error detection..... Yes
- Short circuit detection..... < 15 Ω

Input:

Output:

TC input:

- TC type..... B, E, J, K, L, N, R, S, T, U, W3, W5
- Cold junction compensation (CJC) ... < ±0,5 °C
- Sensor error detection..... Yes
- Sensor error current:
when detecting..... Nom. 4 μA
else..... 0 μA
- Short circuit detection..... < 3 mA

Voltage input:

- Measurement range..... -800...+800 mV
- Input resistance..... 10 MΩ

Output:

FOUNDATION™ Fieldbus connection:

- FOUNDATION™ Fieldbus version..... ITK 4.6
- FOUNDATION™ F. capability..... Basic or LAS
- FOUNDATION™ F. function blocks..... 2 analogue and 1 PID

PROFIBUS® PA connection:

- PROFIBUS® PA protocol standard EN 50170 vol. 2
- PROFIBUS® PA function blocks..... 2 analogue
- PROFIBUS® PA address (at delivery) ... 126

Ex / I.S. approval:

- KEMA 03ATEX1011 X..... II 3 GD Ex nA [nL] IIC T4...T6 or II 3 GD Ex nL IIC T4...T6 or Ex II 3 GD Ex nA [ic] IIC T4...T6 or II 3 GD Ex ic IIC T4...T6

ATEX Installation Drawing No..... 5350QE01

- FM and CSA..... IS, Cl. I, Div. 2, Gr. A, B, C, D
IS, Cl. I, Zone 2, Gr. IIC

- NEPSI..... GYJ04407U
Ex nA (L) IIC T4~T6

GOST R approval:

- VNIIM, Cert. no..... www.prelectronics.com

Observed authority requirements: Standard:

- EMC 2004/108/EC..... EN 61326-1
- ATEX 94/9/EC..... EN 60079-0, -11, -15, -27
- FM..... 3600, 3611
- CSA, CAN / CSA..... C22.2 No. 142, No. 213
- CAN / CSA..... E79-0, -15
- ANSI / UL..... UL 60079-0, -15
- NEPSI..... GB3836.1-2000, GB3836.8-2003