

auma[®]

Electric part-turn actuators

SG 03.3 – SG 04.3
AUMA NORM



Certificate Registration No.
12 100/104 4269

Operation instructions

Scope of these instructions: These instructions apply to part-turn actuators of the type range SG 03.3 – SG 04.3.
These operation instructions are only valid for "clockwise closing", i.e. driven shaft turns clockwise to the valve.

Table of contents		Page
1. Safety instructions		3
1.1	Range of application	3
1.2	Commissioning (electrical connection)	3
1.3	Maintenance	3
1.4	Warnings and notes	3
1.5	Further notes	3
2. Short description		3
3. Technical data		4
4. Transport and storage		5
5. Packaging		5
6. Fitting the ball handle/ manual operation		5
6.1	Fitting the ball handle	5
6.2	Manual operation	5
7. Mounting to valve		6
8. Checking the end stops		7
8.1	Setting of end stop CLOSED	7
8.2	Setting of end stop OPEN	8
8.3	Setting values for mechanical end stops	8
9. Electrical connection		9
9.1	Connection with AUMA plug/ socket connector	9
9.2	Heater	9
9.3	Motor protection	9
9.4	Remote position transmitter	10
9.5	Limit switch	10
9.6	Fitting of the cover	10
10. Setting the limit switching		11
10.1	Setting for end position CLOSED (black section)	11
10.2	Setting for end position OPEN (white section)	12
11. Setting of mechanical position indicator		12
12. Test run		12
13. Setting of the potentiometer (option)		13
14. Setting of electronic position transmitter RWG (option)		13
14.1	Setting of 2-wire system 4 – 20 mA and 4-wire system 0 – 20 mA	14
14.2	Setting of 4-wire system 4 – 20 mA	15
15. Setting of the electronic intermediate position detection (option)		16
16. Maintenance		17
17. Disposal and recycling		17
18. Service		17
19. Proposed wiring diagrams		18
19.1	Wiring diagram for SG with 1-phase AC motors	19
19.2	Wiring diagram for SG with 1-phase AC motors with reversing contactor controls	20
19.3	Wiring diagram for SG with 3-phase AC motors	21
20. Spare parts list part-turn actuator SG 03.3 – SG 04.3		22
21. Declaration of Conformity and Declaration of Incorporation		26
Index		27
Addresses AUMA offices and representatives		28

1. Safety instructions

1.1 Range of application

AUMA part-turn actuators are designed for the operation of industrial valves, e.g. butterfly valves and ball valves. For other applications, please consult us. The manufacturer is not liable for any possible damage resulting from use in other than the designated applications. Such risk lies entirely with the user. Observance of these operation instructions is considered as part of the actuators' designated use.

1.2 Commissioning (electrical connection)

During electrical operation certain parts inevitably carry lethal voltages. Work on the electrical system or equipment must only be carried out by a skilled electrician himself or by specially instructed personnel under the control and supervision of such an electrician and in accordance with the applicable electrical engineering rules.

1.3 Maintenance

The maintenance instructions (refer to page 17) must be observed, otherwise a safe operation of the actuator is no longer guaranteed.

1.4 Warnings and notes

Non-observance of the warnings and notes may lead to serious injuries or damage. Qualified personnel must be thoroughly familiar with all warnings and notes in these operation instructions. Correct transport, proper storage, mounting and installation, as well as careful commissioning are essential to ensure a trouble-free and safe operation. The following references draw special attention to safety-relevant procedures in these operation instructions. Each is marked by the appropriate pictograph.



This pictograph means: Note!

“Note” marks activities or procedures which have major influence on the correct operation. Non-observance of these notes may lead to consequential damage.



This pictograph means: Electrostatically endangered parts!

If this pictograph is attached to a printed circuit board, it contains parts which may be damaged or destroyed by electrostatic discharges. If the boards need to be touched during setting, measurement or for exchange, it must be assured that immediately before a discharge through contact with an earthed metallic surface (e.g. the housing) has taken place.



This pictograph means: Warning!

“Warning” marks activities or procedures which, if not carried out correctly, can affect the safety of persons or material.

1.5 Further notes



This pictograph means: Procedure may have been performed by valve manufacturer!

If actuators are delivered mounted to a valve, this step has been done in the valve manufacturer's plant.

Setting must be checked during commissioning!

2. Short description

AUMA part-turn actuators type SG 03.3 – SG 04.3. have a modular design. Manual operation is possible without change-over. The limitation of travel is realised via limit switches in both end positions. They are sized in such a way that the motor current can be switched directly by them. When a switch is tripped in the end position, the motor power supply is immediately interrupted.

3. Technical data

Table 1: Part-turn actuator SG 03.3 – SG 04.3	
Application	
Part-turn actuator	Electrical operation of valves (e.g. butterfly valves and ball valves).
Features and functions	
Type of duty (according to IEC 34-1)	Short time duty S2 -15 min
Motors	Standard: 1-phase AC motor Option: 3-phase AC motor
Insulation class	F, tropicalized
Motor protection	Standard: Thermoswitches Option: PTC thermistors
Self-locking	yes
Operating times	see table
Swing angle	90° (adjustable from 82° to 98°)
Type of seating	by limit switching
Limit switching	Counter gear mechanism for end positions OPEN and CLOSED Standard: Single switch (1 NC and 1 NO) for each end position Option: Tandem switch (2 NC and 2 NO) for each end position, switches galvanically isolated
Torque switching	not available
Intermediate positions (option)	Electronic intermediate position switches, max. 2 switching points, adjustable (only in combination with electronic position transmitter RWG 6020)
Position feedback signal (options)	Precision potentiometer Electronic position transmitter RWG 6020, 0/4 – 20 mA, voltage supply 24 V DC
Mechanical position indicator	adjustable indicator disc with symbols OPEN and CLOSED, continuous indication
Running indication (option)	in combination with blinker transmitter possible
Heater in switch compartment	Standard: Self-regulating heater, 5 – 20 W 110 – 250 V DC/AC or 24 – 48 V DC/AC Option: Resistance type heater, 5 W, 24 V DC (only in combination with the AUMA controls AM or AC)
Manual operation	Manual drive for setting and emergency operation, handwheel does not rotate during electric operation
Handwheel lockable (option)	yes
Electrical connection	
Electrical connection	Standard: AUMA plug/socket connector with screw type connection Option: Double sealed (double sealed plug/socket connector)
Threads for cable glands	Standard: 1 x M20x1.5, 2 x M25x1.5 Options: Pg thread, NPT thread
Terminal plan	1-phase AC motor: KMS B10101100 (basic version) 3-phase AC motor: KMS A10101100 (basic version)
Valve attachment	
Valve attachment	Dimensions according to EN ISO 5211
Coupling	splined coupling for connection to the valve shaft, part-turn actuator can be repositioned 4 x 90° on coupling Standard: Coupling without bore Options: Machined coupling with bore and keyway, square bore or bore with two-flats
Service conditions	
Enclosure protection according to EN 60 529	Standard: IP 67 Option: IP 68
Corrosion protection	Standard: KN Suitable for installation in industrial units, in water- or power plants with a low pollutant concentration ⁴⁾ Options: KS Suitable for installation in occasionally or permanently aggressive atmosphere with a moderate pollutant concentration (e.g. in wastewater treatment plants, chemical industry) KX Suitable for installation in extremely aggressive atmosphere with high humidity and high pollutant concentration
Ambient temperature	Standard: – 25 °C to + 70 °C
Finish coating	Standard: two-component iron-mica combination
Standard colour	silver-grey (DB 701, similar to RAL 9007)
Other information	
Reference documents	Product description SG 03.3 – SG 04.3 Dimension sheet SG 03.3 – SG 05.3 Electrical data SG 03.3 – SG 04.3

4. Transport and storage

- Transport to place of installation in sturdy packing.
- Do not attach ropes or hooks to the handwheel for the purpose of lifting by hoist.
- If part-turn actuator is mounted on valve, attach ropes or hooks for the purpose of lifting by hoist to valve and not to part-turn actuator.
- Store in well-ventilated, dry room.
- Protect against floor dampness by storage on a shelf or on a wooden pallet.
- Cover to protect against dust and dirt.
- Apply suitable corrosion protection agent to bright surfaces.

If part-turn actuators are to be stored for a long time (more than 6 months), the following points must be observed additionally:

- Prior to storage: Protect bright surfaces, in particular the output drive parts and mounting surface, with long-term corrosion protection agent.
- Check for corrosion approximately every 6 months. If first signs of corrosion show, apply new corrosion protection.

After mounting, connect part-turn actuator immediately to electrical mains, so that condensation is prevented by the heater.

5. Packaging

Our products are protected by special packaging for the transport ex works. The packaging consists of environmentally friendly materials which can easily be separated and recycled.

For the disposal of the packaging material we recommend recycling and collection centres.

We use the following packaging materials:

Wooden material boards (OSB)/cardboard/paper/PE film

6. Fitting the ball handle/ manual operation

To avoid damage during transport, the ball handles are fitted to the inside of the handwheel. Prior to commissioning, the ball handle has to be fitted in the correct position.

6.1 Fitting the ball handle

Figure A1

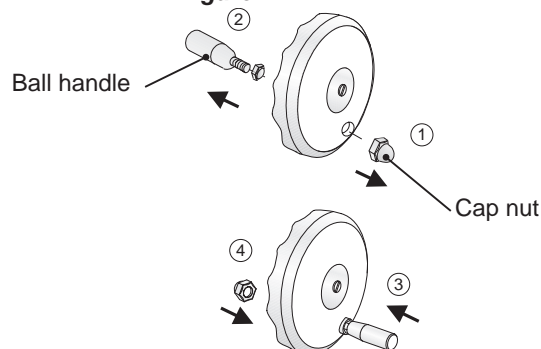

- Remove cap nut.
- Pull out ball handle and re-insert in correct position.
- Fasten with cap nut.
- Remove sticker from the hand wheel for fitting the ball handle.

6.2 Manual operation

Manual operation is activated by turning the handwheel. A change-over is not required. The handwheel does not rotate during motor operation.



Turning the handwheel during motor operation results in an extension or reduction of the operating time, depending on the direction of rotation.

7. Mounting to valve



- Prior to mounting the part-turn actuator must be checked for any damage.
- Damaged parts must be replaced by original spare parts.
- After mounting to valve, touch up any possible damages to paint finish.

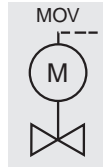

- For **butterfly valves** the recommended mounting position is end position CLOSED. (Prior to mounting, bring the part-turn actuator to the mechanical end stop CLOSED by turning the handwheel clockwise).
- For **ball valves** the recommended mounting position is end position OPEN. (Prior to mounting, bring the part-turn actuator to the mechanical end stop OPEN by turning the handwheel counter-clockwise).
- Thoroughly degrease mounting faces of part-turn actuator and valve.
- Place coupling sleeve on to valve shaft and secure (refer to figure A2, detail A or B), ensure that dimensions X, Y and Z are observed (refer to table 2).
- Apply non-acidic grease at splines of coupling.
- Fit actuator so that fixing holes in actuator and valve mounting flange are in alignment. If necessary, move actuator up or down one tooth on the coupling. If required, turn handwheel a little in direction OPEN or CLOSE until holes align to the threads.
- Ensure that the spigot (if provided) mates uniformly in the recess and that the mounting faces are in complete contact.
- Fasten the actuator with bolts of minimum quality 8.8 using lock washers. Fasten bolts crosswise to the appropriate torque according to table 2.

Figure A2

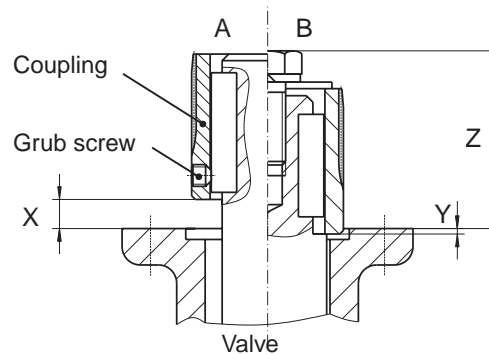

Table 2

Type	X max	Y max	Z max	8.8	T _A [Nm]
SG 03.3/04.3-F04	10	0	37	4 x M 5	6
SG 03.3/04.3-F05	8	2	35	4 x M 6	11
SG 03.3/04.3-F07	8	2	35	4 x M 8	25

8. Checking the end stops

This check can only be performed on valves which are not yet mounted into a pipeline.

8.1 Setting of end stop CLOSED

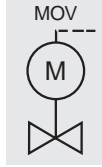

- Check whether mechanical end position of the valve corresponds to the mechanical end stop of actuator by turning at handwheel (clockwise for end position CLOSED)
- If necessary, remove screw plug (22.1, figure B1) and adjust mechanical end stop at hex. socket head cap screw (21.1, figure B3). Turning clockwise results in smaller, turning counter-clockwise results in larger swing angles.



- **Never remove the screws (21.2, figure B2 and 21.1, figure B3) completely, because this will cause oil leakage.**
- **Observe dimension T_{min} . (subclause 8.3).**

- Check O-ring in screw plug and replace if damaged.
- Replace and fasten screw plug (22.1, figure B1).

Figure B1

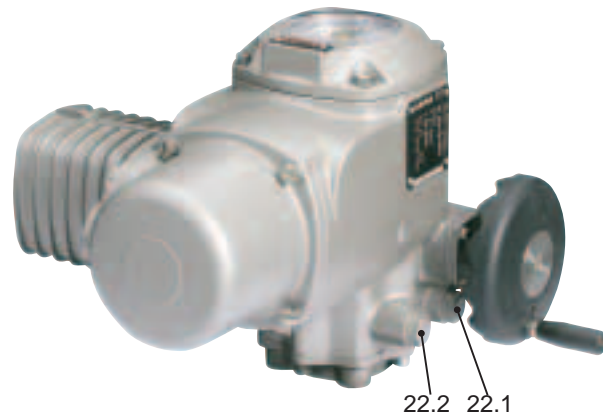
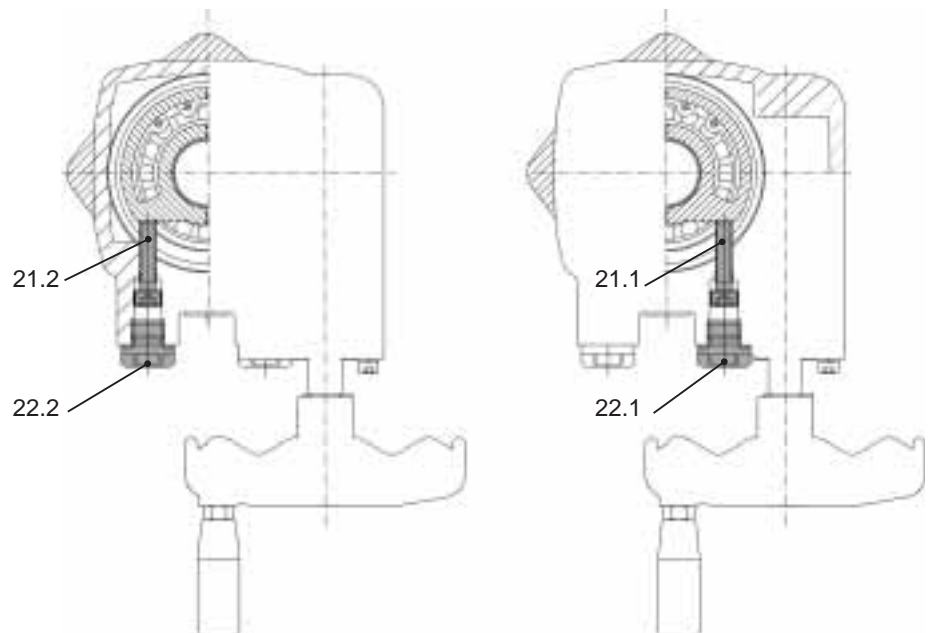
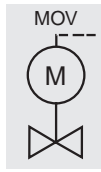

Fig. B2: Setting end position OPEN (view from top) Fig. B3: Setting end position CLOSED (view from top)



8.2 Setting of end stop OPEN



The swing angle has been set in the factory to approx. 90° or to the swing angle stated in the order. An adjustment might be necessary if the end stop CLOSED has been re-adjusted.

- Check whether mechanical end position of the valve corresponds to the mechanical end stop of actuator by turning at handwheel (counter-clockwise for end position OPEN)
- If necessary, remove screw plug (22.2, figure B2) and adjust mechanical end stop at hex. socket head cap screw (21.2, figure B2).
- Check O-ring in screw plug and replace if damaged.
- Replace and fasten screw plug (22.2).

8.3 Setting values for mechanical end stops

Figure B4: (view from top)

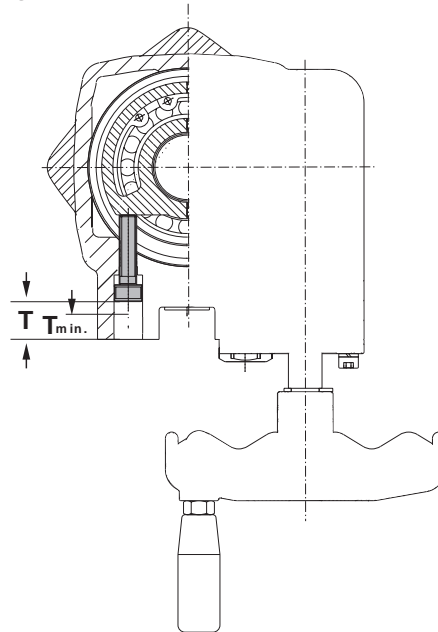
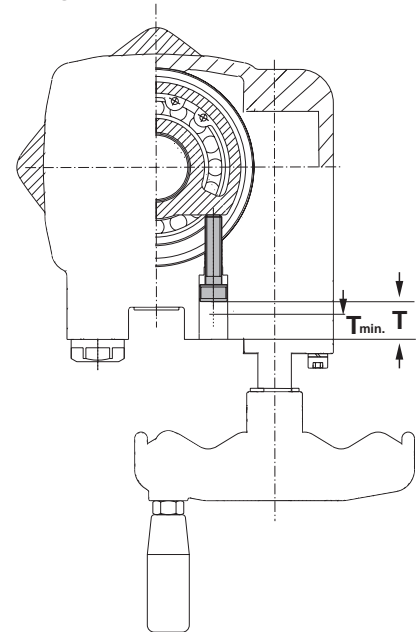

Figure B5: (view from top)



Basic factory setting for 90° swing angle:

Swing angle ¹⁾	SG 03.3/04.3	
Dimension T (factory setting)	mm	13.5
Dimension T _{min.} ²⁾	mm	9

1) By turning at the hex. socket head cap screw for end stop CLOSED or OPEN the end position changes accordingly.
The swing angle can be checked and set by using the dimension T.

2) If T_{min.} is not reached, the gearing might be damaged.

For each turn of the hex. socket head cap screw, the setting of the end position changes by:

for clockwise turn approx.:	3.3°
for counter-clockwise turn approx.:	2.4°



The limitation of travel is realised via limit switches (page 11) in both end positions. For this reason the end stops of the actuator have to be set to a slightly larger swing angle (approx. by 2° larger) than the swing angle actually required by the valve.

9. Electrical connection



Work on the electrical system or equipment must only be carried out by a skilled electrician himself or by specially instructed personnel under the control and supervision of such an electrician and in accordance with the applicable electrical engineering rules.

9.1 Connection with AUMA plug/ socket connector

Figure C1: Connection

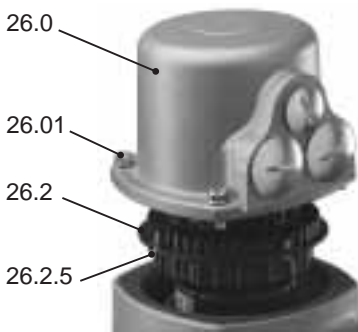

- Check whether type of current, supply voltage and frequency correspond to motor data (refer to name plate at motor).
- Loosen bolts (26.01) (figure C1) and remove plug cover (26.0).
- Loosen screws (26.2.5) and remove socket carrier (26.2) from plug cover (26.0).
- Insert cable glands suitable for connecting cables.



- **Enclosure protection IP 67 or IP 68 is only ensured if suitable cable glands are used.**
- **Seal cable entries which are not used with suitable plugs.**

- Connect cables according to order related terminal plan KMS The terminal plan applicable to the actuator is attached to the handwheel in a weather-proof bag, together with the operation instructions. In case the wiring diagram is not available, it can be obtained from AUMA (state commission no., refer to name plate) or downloaded directly from the Internet (see page 27).

Figure C2: Parking frame (accessory)

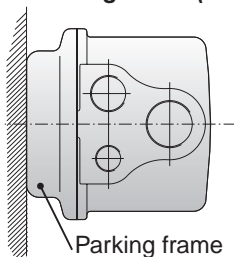

A special parking frame for protection against touching the bare contacts and against environmental influences is available (see address list page 28).

Table 3: Technical data AUMA plug/ socket connector

Technical data	Motor power connections ¹⁾	Protective earth	Control pins
No. of contacts max.	6 (3 are used)	1 (leading contact)	50 pins / sockets
Marking	U1, V1, W1, U2, V2, W2	according to VDE	1 to 50
Voltage max.	750 V	–	250 V
Current max.	25 A	–	16 A
Type of customer connection	Screws	Screw for ring lug	Screws
Cross section max.	6 mm ²	6 mm ²	2.5 mm ²
Material:Pin / socket carrier	Polyamide	Polyamide	Polyamide
Contacts	Brass (Ms)	Brass (Ms)	Brass, tin plated or gold plated (option)

1) Suitable for copper wires. For aluminium wires contact AUMA.

9.2 Heater

AUMA part-turn actuators have a heater installed as standard. To prevent condensation, the heater must be connected. Refer to proposed wiring diagrams on pages 19 and 20.

9.3 Motor protection

In order to protect against overheating a thermoswitch is embedded in the motor windings and has to be connected to the external control circuit. The thermoswitch is tripped as soon as the max. permissible windings temperature is reached. After the motor has cooled down to a temperature of approx. 90 °C, the actuator can be switched on again. Our warranty for the motor will lapse if the thermoswitch is not connected.

9.4 Remote position transmitter

For the connection of position transmitters (potentiometer, RWG) screened cables must be used.

9.5 Limit switch

Only the same potential can be switched on the two circuits (NC/ NO contact) of each single switch. If different potentials are to be switched simultaneously, tandem switches are required.

For correct signalisation, the leading contacts must be connected at the tandem switch.

I Single switch

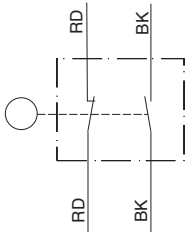

II Tandem switch
Signalisation Switching off

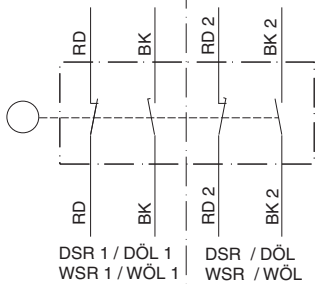

9.6 Fitting of the cover

Table 4: Technical data limit and torque switches

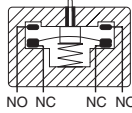
			
Mechanical lifetime = 2 x 10 ⁶ cycles			
Type of current	Switch rating I _{max}		
	30 V	125 V	250 V
1-phase AC (ind. load) cos phi = 0.8	5 A	5 A	5 A
DC (resistive load)	2 A	0.5 A	0.4 A
with gold plated contacts	min. 5 V, max. 50 V		
Current	min. 4 mA, max. 400 mA		

- (26.2), see figure 8, page 6, into the plug cover and fasten it with screws (2).
- Clean sealing faces at plug cover (26.0) and check whether O-ring is in good condition. Apply a thin film of non-acidic grease (e.g. Vaseline) to the sealing faces.
 - Replace plug cover (26.0) and fasten 4 bolts (26.01) evenly crosswise.
 - Fasten cable glands firmly to ensure required enclosure protection.

10. Setting the limit switching



- Take off cover at switch compartment.
- Pull off indicator disc (figure D). Open end spanner (approx. 14 mm) may be used as lever.

Figure D

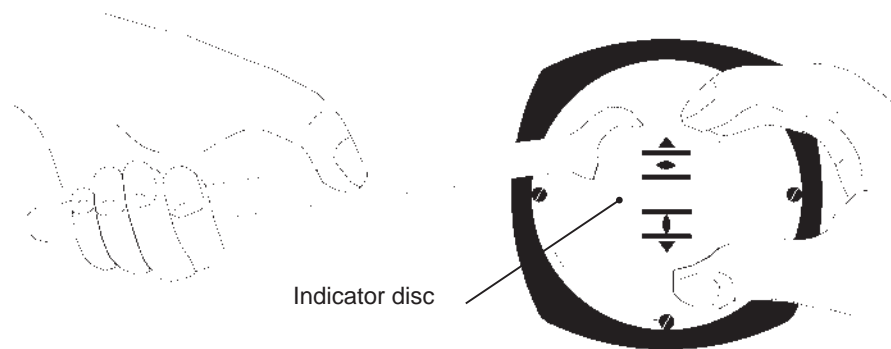

These operation instructions are only valid for “clockwise closing”, i.e. driven shaft turns clockwise to close the valve.

10.1 Setting for end position CLOSED (black section)

- Turn handwheel clockwise until valve is closed.
- Turn handwheel approx. 1 turn in direction OPEN and then half a turn in direction CLOSED.
- **Press down** and turn setting spindle A (figure E) with screw driver (5 mm) in direction of arrow, thereby observe switch cam B. While a ratchet is felt and heard, the switch cam B moves 90° every time. When switch cam B is 90° from the switch, continue turning slowly. When the switch cam B snaps and trips the switch, stop turning and release setting spindle. If you override the tripping point inadvertently (ratchet is heard after the switch cam has snapped), continue turning the setting spindle in the same direction and repeat the setting process.

Figure E

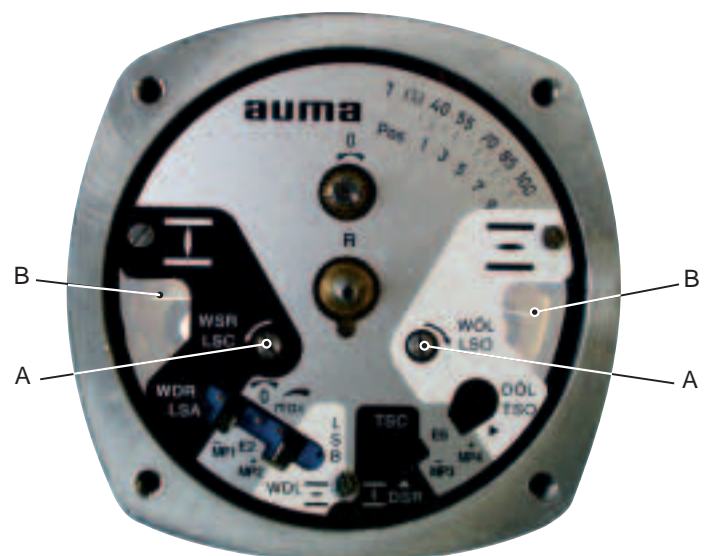

10.2 Setting for end position OPEN (white section)

- Turn handwheel counter-clockwise until valve is open.
- Turn handwheel approx. 1 turn in direction CLOSE and then half a turn in direction OPEN.
- **Press down** and turn setting spindle D (figure E) with screw driver (5 mm) in direction of arrow, thereby observe switch cam E. While a ratchet is felt and heard, the switch cam E moves 90° every time. When switch cam E is 90° from the switch, continue turning slowly. When the switch cam E snaps and trips the switch, stop turning and release setting spindle.
If you override the tripping point inadvertently (ratchet is heard after the switch cam has snapped), continue turning the setting spindle in the same direction and repeat the setting process.

11. Setting of mechanical position indicator

Indicator disc rotates approximately 90° at full travel from OPEN to CLOSED or vice versa.



- Place indicator disc (figure F) on shaft.
- Move valve to end position CLOSED.
- Turn lower indicator disc until symbol  CLOSED is in alignment with the mark on the cover (figure L).
- Move actuator to end position OPEN.
- Hold lower indicator disc in position and turn upper disc with symbol  OPEN until it is in alignment with the mark on the cover.

Figure F



12. Test run

Check limit switching:

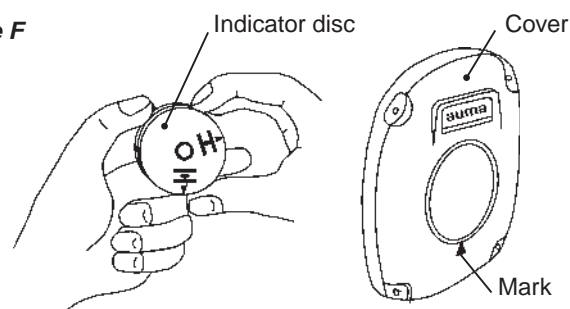
- Move actuator manually (refer to page 5, clause 6.2) into both end positions of the valve.
- Check whether limit switching is set correctly. Hereby observe that the appropriate switch is tripped in each end position and released again after the direction of rotation is changed. If this is not the case, the limit switching must first be set, as described from page 11.

If no optional components (clauses 13. to 15.) require setting:

- Clean sealing faces at cover and housing; check whether O-ring is in good condition. Apply a thin film of non-acidic grease to the sealing faces.
- Replace cover on switch compartment and fasten bolts evenly crosswise.

13. Setting of the potentiometer (option)

– For remote indication –

- Move valve to end position CLOSED.
- Take off cover at switch compartment.
- Pull off indicator disc.
- Turn potentiometer (R) counter-clockwise until stop is felt. End position CLOSED corresponds to 0 %, end position OPEN to 100 %.
- Turn potentiometer (R) slightly back from the stop.
- Perform fine-tuning of the zero point at external setting potentiometer (for remote indication).
- Press indicator disc on shaft and perform setting as described on page 12, clause 9.
- Clean sealing faces at cover and housing; check whether O-ring is in good condition. Apply a thin film of non-acidic grease to the sealing faces.
- Fit and fasten switch compartment cover.

Figure H

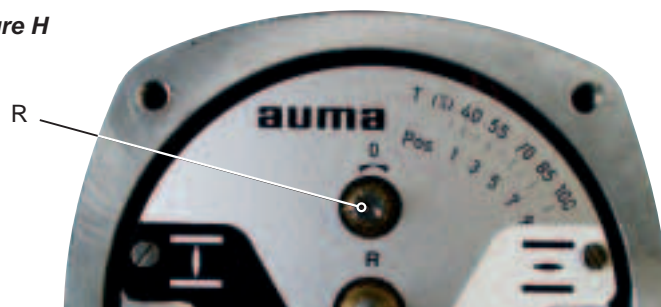

14. Setting of electronic position transmitter RWG (option)

– For remote indication or external control –

After mounting the part-turn actuator to the valve, check setting by measuring the output current (see subclause 14.1 or 14.2) and re-adjust, if necessary.

Table 5: Technical data RWG 6020

Terminal plans		KMS _ _ _ _ R _ / _ _	KMS _ _ _ _ Z _ / _ _ KMS _ _ _ _ Z _ / _ _
		4-wire system	2-wire system
Output current	I_a	0 – 20 mA, 4 – 20 mA	4 – 20 mA
Supply voltage	U_v	24 V DC, $\pm 15\%$ smoothed	12 V DC + ($I \times R_B$), max. 30 V
Max. input current	I	25 mA at 20 mA output current	20 mA
Max. load	R_B	600 Ω	$(U_v - 12 \text{ V}) / 20 \text{ mA}$

14.1 Setting of 2-wire system 4 – 20 mA and 4-wire system 0 – 20 mA

The 2-wire system cannot be used in combination with the intermediate position detection (page 16).



- Connect voltage for electronic position transmitter.
- Move valve to end position CLOSED.
- Take off cover at switch compartment.
- Pull off indicator disc.
- Connect ammeter for 0 – 20 mA to measuring points (MP1/MP2) (figure J).

In end position CLOSED with 4-wire system the value after setting must be 0 mA, for 2-wire system it must be 4 mA.



The circuit (external load) must be connected (observe max. ext. load R_B), or the appropriate poles at the AUMA plug/ socket connector must be linked (refer to terminal plan), otherwise no value can be measured.

- Turn potentiometer (R) counter-clockwise until stop is felt.
- Turn potentiometer (R) slightly back from the stop.

Figure H



- Turn trimmer potentiometer (R6 - "0") clockwise until output current starts to increase.
- Turn back trimmer potentiometer (R6 - "0") until a residual current of approx. 0.1 mA (or 4.1 mA in case of 2-wire system) is reached. This ensures that the signal remains above the dead and live zero point.
- Move valve to end position OPEN.
- Set to end value 20 mA with trimmer potentiometer (R5 - "max.").
- Approach end position CLOSED anew and check minimum value (0 mA or 4 mA). If necessary, correct the setting.
- Press indicator disc on shaft and perform setting as described on page 12, clause 9.
- Clean sealing faces at cover and housing; check whether O-ring is in good condition. Apply a thin film of non-acidic grease to the sealing faces.
- Replace cover on switch compartment and fasten bolts evenly crosswise.

Figure J

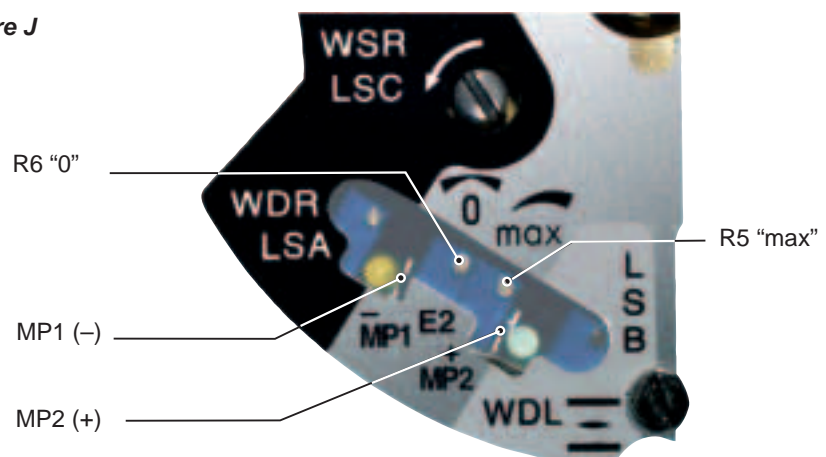

14.2 Setting of 4-wire system 4 – 20 mA



- Connect voltage for electronic position transmitter.
- Move valve to end position CLOSED.
- Take off cover at switch compartment.
- Pull off indicator disc.
- Connect ammeter for 0 – 20 mA to measuring points (MP1/MP2) (figure J).



The circuit (external load) must be connected (observe max. ext. load R_B), or the appropriate poles at the AUMA plug/ socket connector must be linked (refer to terminal plan), otherwise no value can be measured.

- Turn potentiometer (R, figure H) counter-clockwise until stop is felt.
- Turn potentiometer (R) slightly back from the stop.
- Turn trimmer potentiometer (R6 - "0", figure J) clockwise until output current starts to increase.
- Turn back potentiometer (R6 - "0") until a residual current of approx. 0.1 mA is reached.
- Move valve to end position OPEN.
- Set trimmer potentiometer (R5 - "max.") to end value 16 mA.
- Move valve to end position CLOSED.
- Set potentiometer (R5 - "max.") from 0.1 mA to initial value 4 mA. This results in a simultaneous shift of the end value by 4 mA, so that the range is now 4 – 20 mA.
- Approach both end positions anew and check setting. If necessary, correct the setting.
- Press indicator disc on shaft and perform setting as described on page 12, clause 9.
- Clean sealing faces at cover and housing; check whether O-ring is in good condition. Apply a thin film of non-acidic grease to the sealing faces.
- Replace cover on switch compartment and fasten bolts evenly crosswise.

15. Setting of the electronic intermediate position detection (option)

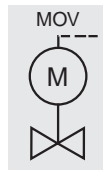

Any application can be switched **on or off** via the two intermediate position switches WDR/LSA and WDL/LSB.

The intermediate position detection is set in the factory according to order details. If the customer requirements have not been mentioned in the order, the intermediate positions have been set to 5 mA (WDR/LSA) and 15 mA (WDL/LSB)

In case other intermediate positions are required they have to be set as follows:

- Connect voltage for electronic position transmitter.
- Take off cover at switch compartment.

Figure K

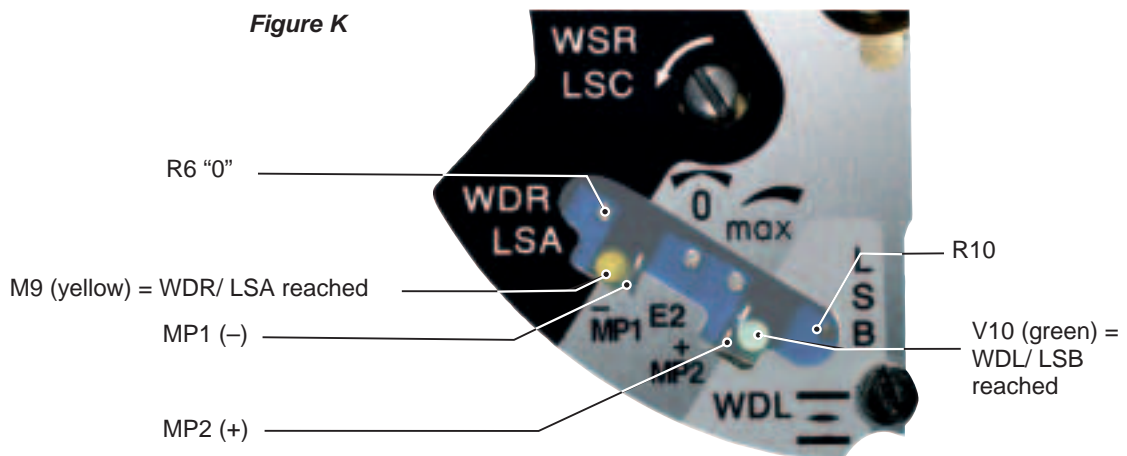

Table 6

No	Colour	Function	Description
V9	yellow	is illuminated: WDR/LSA reached	The current, and consequently, the position have reached the set value
		is not illuminated: no WDR/LSA	The intermediate position WDR/LSA has not yet been reached
V10	green	is illuminated: WDL/LSB reached	The current, and consequently, the position have reached the set value
		is not illuminated: no WDR/LSB	the intermediate position WDL/LSB has not yet been reached

- Move valve to end position CLOSED.
- Connect ammeter for 0 – 20 mA to measuring points (MP1/ MP2). (Measured value for normal operation = 0 mA or 4 mA, for inverse operation = 20 mA)
- Turn trimmer potentiometer (R9) clockwise, until the yellow LED V9 is no longer illuminated.
- Move valve in direction OPEN. Stop the actuator when reaching the desired intermediate position (WDR/LSA).
- Turn trimmer potentiometer (R9) counter-clockwise, until the yellow LED V9 is illuminated. The intermediate position WDR/LSA is now set.
- Move valve to end position OPEN. (Measured value for normal operation = 20 mA, for inverse operation = 0 mA or 4 mA)
- Turn trimmer potentiometer (R10) counter-clockwise, until the green LED V10 is no longer illuminated.
- Move valve in direction CLOSE. Stop the actuator after reaching the desired intermediate position (WDL/LSB).
- Turn trimmer potentiometer (R10) clockwise, until the green LED V10 is illuminated. The intermediate position WDR/LSB is now set.
- Clean sealing faces at cover and housing; check whether O-ring is in good condition. Apply a thin film of non-acidic grease to the sealing faces.
- Replace cover on switch compartment and fasten bolts evenly crosswise.

16. Maintenance

After commissioning, check part-turn actuator for damage to paint finish. Do a thorough touch-up to prevent corrosion. Original paint in small quantities can be supplied by AUMA.

AUMA part-turn actuators require very little maintenance. Precondition for reliable service is correct commissioning.

Seals made of elastomers are subject to aging and must therefore regularly be checked and, if necessary, exchanged.

It is also very important that the O-rings at the covers are placed correctly and cable glands fastened firmly to prevent ingress of dirt or water.

We recommend additionally:

- If operated seldom, perform a test run about every 6 months. This ensures that the actuator is always ready to operate.
- Approximately six months after commissioning and then every year check bolts between part-turn actuator and valve for tightness. If required, tighten applying the torques given in table 1, page 5.

The gear housing is filled with lubricant in the factory. This filling lasts for several years of service.

17. Disposal and recycling

AUMA actuators have an extremely long lifetime. However, there will come a time when you have to replace them.

Our actuators have a modular design and may therefore easily be disassembled, separated and sorted according to materials, i.e.:

- electronic scrap
- various metals
- plastics
- greases and oils

The following generally applies:

- Collect greases and oils during disassembly. As a rule, these substances are hazardous to water and must not be released into the environment.
- See disassembled material to a sound disposal or to separate recycling according to materials.
- Observe the national regulations for waste disposal.

18. Service

AUMA offers extensive services such as maintenance and inspection for actuators. Addresses, AUMA offices and representatives can be found on page 28 and on the Internet (www.auma.com).

19. Proposed wiring diagrams

Legend for the proposed wiring diagrams on pages 19 and 20
(included in AUMA delivery)

S 3 / WSR	Limit switch, closing, clockwise rotation
S 4 / LSO	Limit switch, opening, counter-clockwise rotation
F 1 / TH	Thermoswitch (motor protection)
R 1 / H	Heater
R 2 / f1	Potentiometer
S 12	Local control switch OPEN – STOP – CLOSE
XA	Customer connection at the AUMA plug/ socket connector
CB	Capacitor (1 or 2 pieces)

19.1 Wiring diagram for SG with 1-phase AC motors

(Legend page 18)

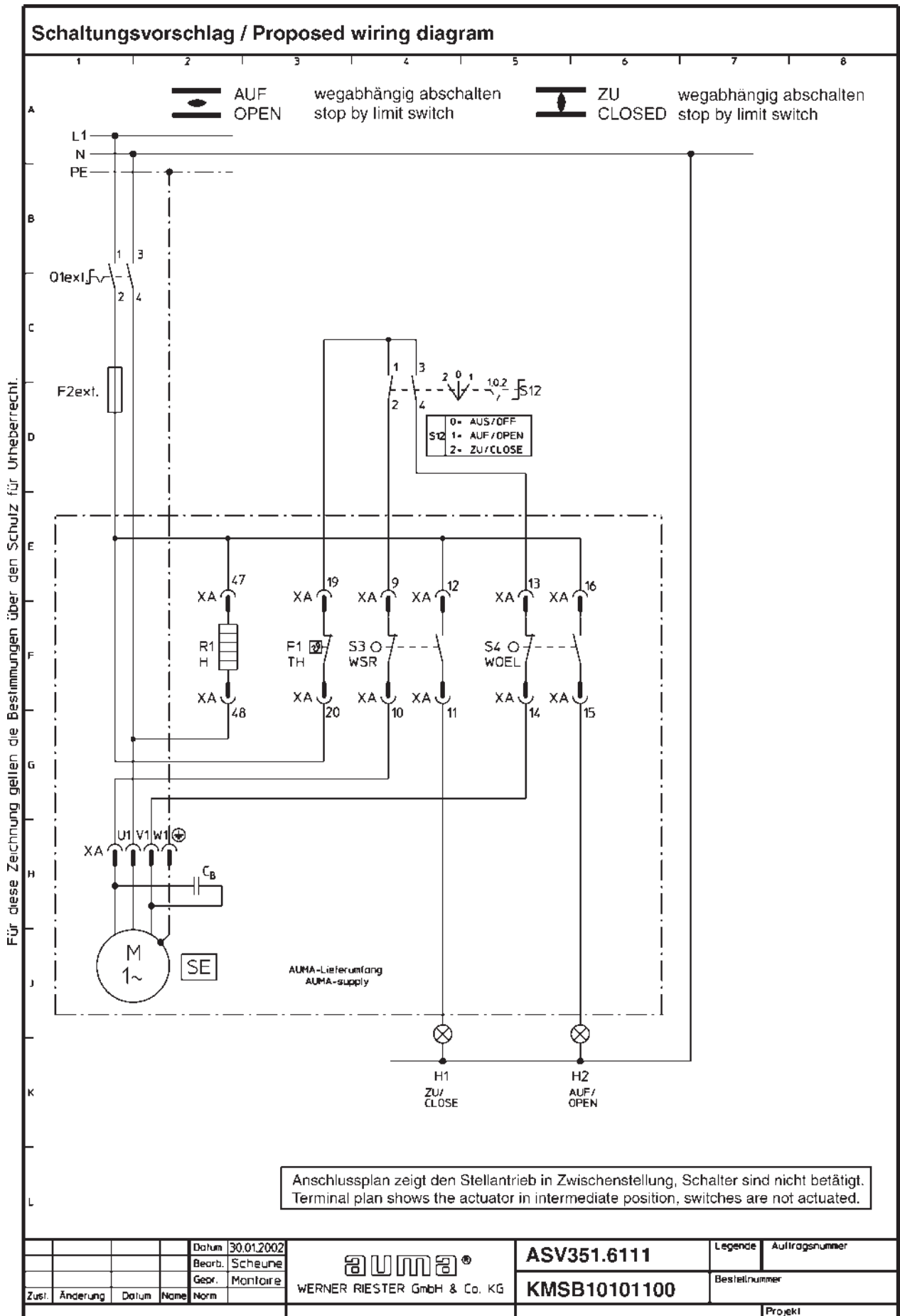

19.2 Wiring diagram for SG with 1-phase AC motors with reversing contactor controls (Legend page 18)

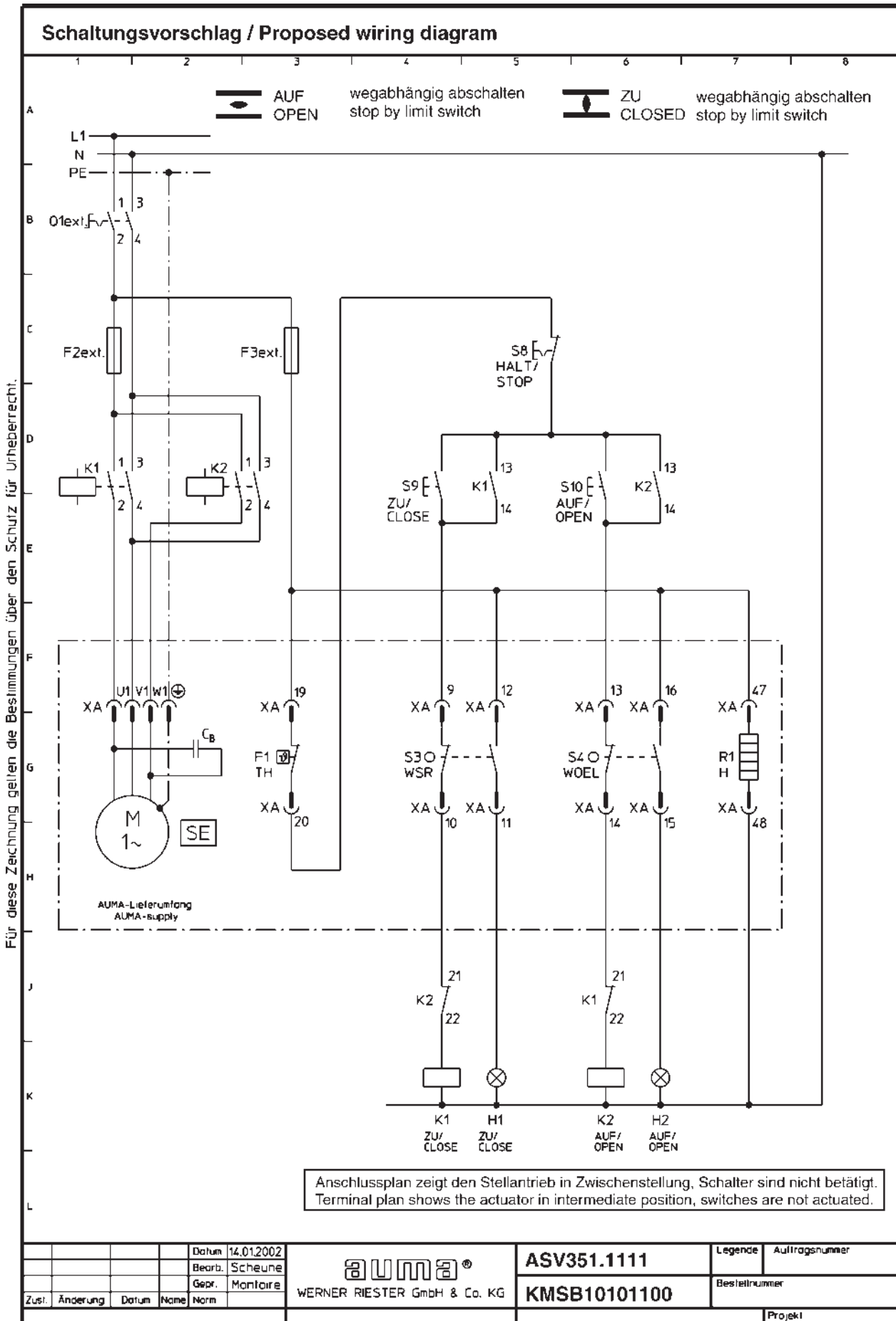

19.3 Wiring diagram for SG with 3-phase AC motors

(Legend page 18)

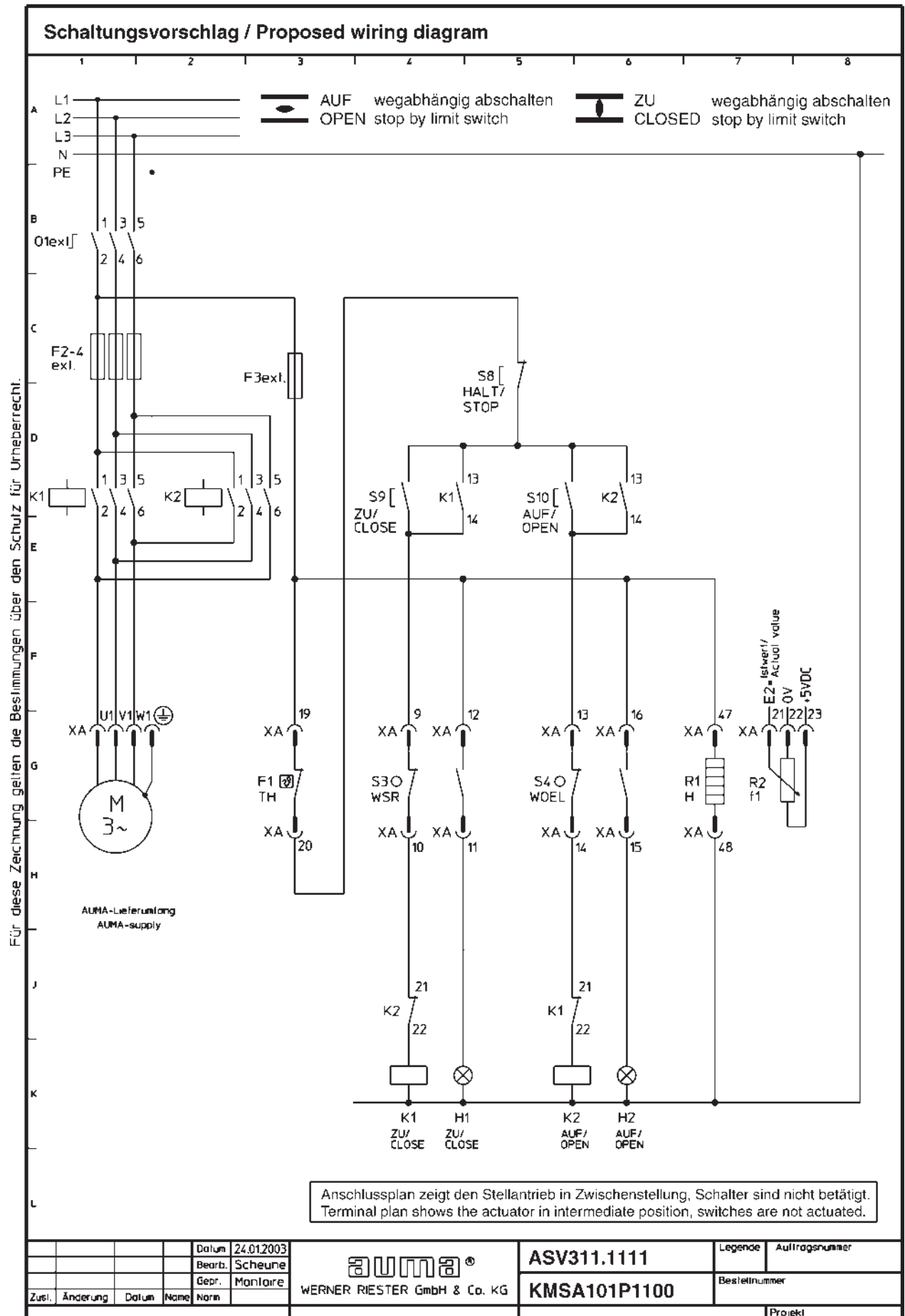

20. Spare parts list part-turn actuator SG 03.3 – SG 04.3

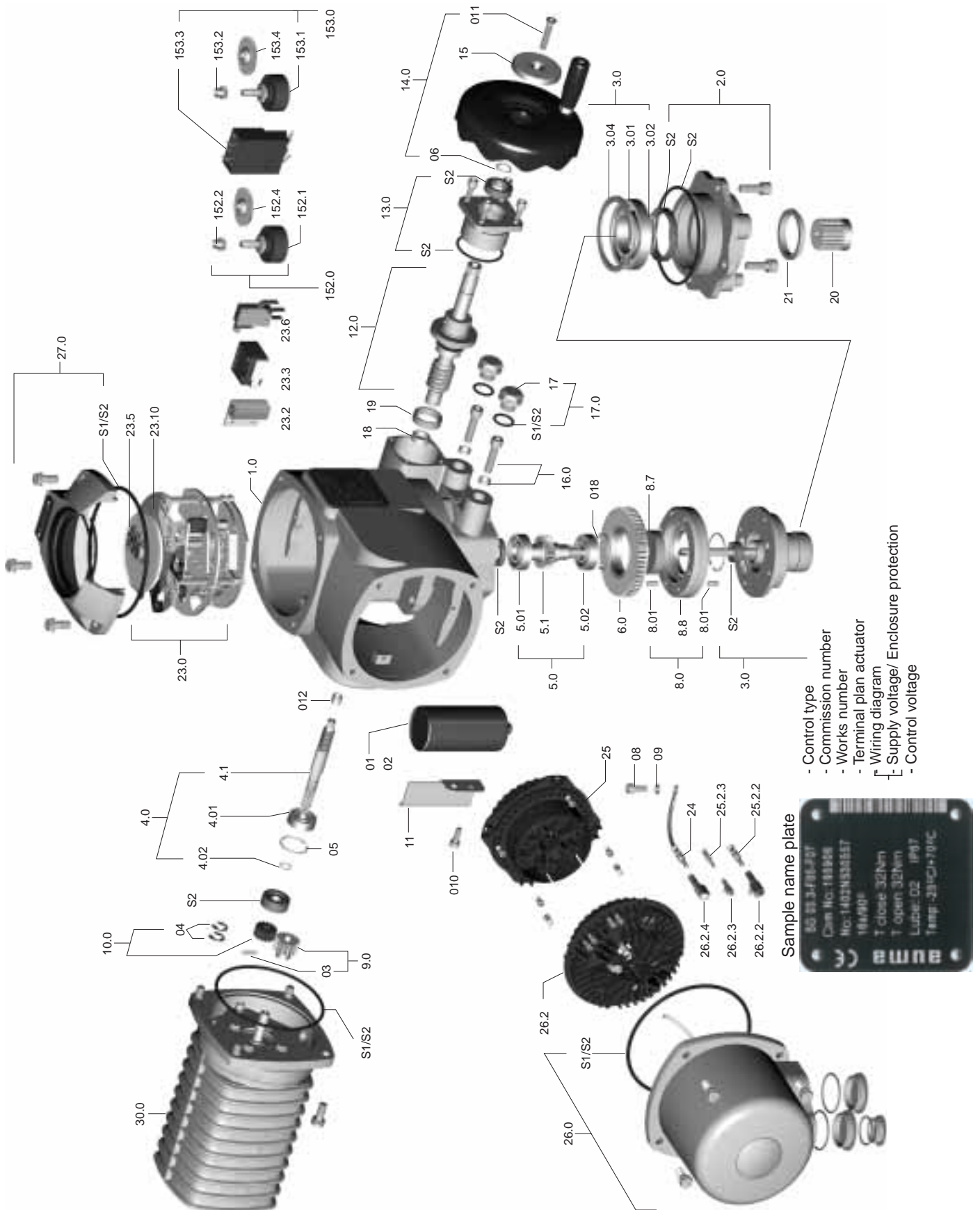

Note:

When placing your order for spare parts , please mention type of part-turn actuator and our commission number (refer to name plate).

No.	Type	Designation	No.	Type	Designation
01	E	Capacitor	17	E	Screw plug
02	E	Capacitor	17.0	B	Screw plug assly.
03	E	Spring dowel	18	E	Bearing bush
04	E	Retaining washer	19	E	Bearing bush
05	E	Circlip	20	E	Coupling
06	E	Retaining washer	21	E	Spigot ring
08	E	Screw	23.0	B	Control unit assly.
09	E	Lock washer	23.2	B	Heater
010	E	Verbus-Tensilock screw	23.3	B	Switch
011	E	Countersunk screw	23.5	B	Mechanical position indicator
012	E	Bearing bush	23.6	B	Blinker transmitter
018	E	Circlip	23.10	E	Cover plate
1.0	B	Housing	24	B	Wire for protective earth
2.0	B	Mounting flange assly.	25	B	Pin carrier assly. (without pins)
3.0	B	Drive wheel assly.	25.2.2	B	Pin for motor
3.01	E	Ball bearing	25.2.3	B	Pin for control
3.02	E	Circlip	26.0	B	Plug cover assly.
3.04	E	Circlip	26.2	B	Socket carrier assly. (complete with sockets)
4.0	B	Worm shaft assly.	26.2.2	B	Socket for motor (included in sub-assembly 26.2)
4.01	E	Ball bearing	26.2.3	B	Socket for control (included in sub-assembly 26.2)
4.02	E	Circlip	26.2.4	B	Socket for protective earth (included in sub-assembly 26.2)
4.1	E	Worm shaft	27.0	B	Cover assly.
5.0	B	Worm wheel shaft assly.	30.0	B	Motor assly.
5.01	E	Ball bearing	152.0	B	Potentiometer assly. ¹⁾
5.02	E	Ball bearing	152.1	E	Potentiometer ¹⁾
5.1	E	Worm wheel shaft	152.2	E	Slip clutch for potentiometer ¹⁾
6.0	B	Worm wheel assly.	152.4	E	Pinion for potentiometer ¹⁾
8.0	B	Ellipto-centric gearing assly.	153.0	B	Electronic position transmitter RWG 6020 ¹⁾
8.01	E	Dowel pin	153.1	E	Potentiometer for RWG 6020 (without slip clutch) ¹⁾
8.7	E	Coupling disc	153.2	E	Slip clutch for RWG 6020 ¹⁾
8.8	B	Ellipto-centric gearing	153.3	E	Electronic board RWG 6020 ¹⁾
9.0	B	Motor pinion assly.	153.4	E	Pinion for RWG 6020 ¹⁾
10.0	B	Spur gear assly.	S1	S	Set of seals, small
11	E	Cable protection	S2	S	Set of seals, large
12.0	B	Worm shaft manual drive assly.			
13.0	B	Retaining flange assly.			
14.0	B	Handwheel assly.			
15	E	Cover disc			
16.0	B	Hex. socket head cap screw - limit stop assly.			

Type B = Sub-assembly Type E = Component Type S = Set assly. = assembly

1) optional extra, not included in basic equipment

Notes

Notes

21. Declaration of Conformity and Declaration of Incorporation

auma®

EC - Declaration of Conformity
according to the directive of the Council for
the approximation of the laws of the Member States
relating to the EMC Directive (89/336/EEC) and
the Low Voltage Equipment Directive (73/23/EEC)

AUMA part-turn actuators of the type ranges

SG 03.3 - SG 05.3
in versions AUMA NORM,
AUMA SEMIPACT, AUMA MATIC
AUMATIC and SIMPACT

are designed and produced to be installed on industrial valves.

Messrs. AUMA Riester GmbH & Co. KG as the manufacturer declares herewith, that the
above mentioned electric AUMA part-turn actuators are in compliance with the following
directives:

- Directive on Electromagnetic Compatibility (EMC) (89/336/EEC)
- Low-Voltage Equipment Directive (73/23/EEC)

The compliance testing of the devices was based on the following standards:

- a) concerning the Directive on Electromagnetic Compatibility
EN 61000-6-4: 08/2002
EN 61000-5-2: 08/2002
EN 61800-3: 02/2001
- b) concerning the Low-Voltage Equipment Directive
EN 60204-1
EN 60034-1
VDE 0100-410

auma®

AUMA Riester GmbH & Co. KG
Armaturen- und Maschinenantriebe
P.O. Box 13 62 • D- 79373 Müllheim / Baden
Tel 07631 / 809-0 • Fax 07631 / 809-250

Müllheim, December 2, 2003

H. Newerth, Managing Director

This declaration does not include any guarantee for certain characteristics.
The safety instructions in the product documentation supplied with the actuators must be observed.

auma®

Declaration of Incorporation
according to EC - Machinery Directive 98/37/EC
article 4 paragraph 2 (Annex II B)

AUMA part-turn actuators of the type ranges

SG 03.3 - SG 05.3
in versions AUMA NORM,
AUMA SEMIPACT, AUMA MATIC,
AUMATIC and SIMPACT

are designed to be installed on valves.

Messrs. AUMA Riester GmbH & Co. KG (manufacturer) declares herewith, that when
designing the above mentioned electric AUMA multi-turn actuators the following stan-
dards were applied:

EN 292 -1
EN 292 -2
EN 60 204 -1

EN VDE 0100-410
EN 60034-1
EN ISO 5211

AUMA multi-turn actuators covered by this Declaration must not be put into service until
the entire machine, into which they are incorporated, has been declared in conformity
with the provisions of the Directive.

auma®

AUMA Riester GmbH & Co. KG
Armaturen- und Maschinenantriebe
P.O. Box 13 62 • 79373 Müllheim / Baden
Tel 07631 / 809-0 • Fax 07631 / 809-250

Müllheim, December 2, 2003

H. Newerth, Managing Director

This declaration does not include any guarantee for certain characteristics.
The safety instructions in the product documentation supplied with the actuators must be observed.

Index

D		M	
Declaration of Conformity	26	Maintenance	3,17
Declaration of Incorporation	26	Manual operation	5
E		Mechanical position indicator	12
Electrical connection	9	Motor protection	9
Electronic position transmitter		Mounting to valve	6
RWG	13	P	
2-wire system	13,14	Parking frame	9
4-wire system	13,14,15	Plug/ socket connector	9
End stops	8	Position indicator	12
F		Position transmitter RWG	13
Fitting the ball handle	5	Potentiometer	13
H		Proposed wiring diagram	19
Heater	9	R	
I		Remote indication	13
Indicator disc	12	S	
Intermediate position detection	16	Safety instructions	3
Internet	27	Service	17
L		Spare parts list	22,23
Legend for the proposed wiring diagram	18	Storage	5
Limit switch	10	Swing angle	8
Limit switching	11	T	
Lubrication	17	Tandem switch	10
		Technical data	4
		Test run	12
		Thermoswitch	9
		Transport	5

Information also available on the Internet:

Terminal plan, inspection records and further actuator information can be downloaded directly from the internet by entering the order no. or comm no. (refer to name plate)..
Our homepage: <http://www.auma.com>

auma®

Solutions for a world in motion

Europe

AUMA Riester GmbH & Co. KG

Werk Müllheim
DE-79373 Müllheim
Tel +49 7631 809 - 0
riester@auma.com
www.auma.com

Werk Ostfildern-Nellingen
DE-73747 Ostfildern
Tel +49 711 34803 - 0
riester@wof.auma.com

Service-Center Köln
DE-50858 Köln
Tel +49 2234 2037 - 9000
Service@sck.auma.com

Service-Center Magdeburg
DE-39167 Niederdodeleben
Tel +49 39204 759 - 0
Service@scm.auma.com

Service-Center Bayern
DE-85386 Eching
Tel +49 81 65 9017 - 0
Riester@scb.auma.com

Büro Nord, Bereich Schiffbau
DE-21079 Hamburg
Tel +49 40 791 40285
Stephan.Dierks@auma.com

Büro Nord, Bereich Industrie
DE-29664 Walsrode
Tel +49 5167 504
Erwin.Handwerker@auma.com

Büro Ost
DE-39167 Niederdodeleben
Tel +49 39204 759 - 9480
Claus.Zander@auma.com

Büro West
DE-45549 Sprockhövel
Tel +49 2339 9212 - 0
Karlheinz.Spoede@auma.com

Büro Württemberg
DE-73747 Ostfildern
Tel +49 711 34803 - 3080
Siegfried.Koegler@wof.auma.com

Büro Süd-West
DE-74937 Spechbach
Tel +49 6226 786141
Rudolf.Bachert@auma.com

Büro Baden
DE-76764 Rheinzabern
Tel +49 7272 76 07 - 23
Wolfgang.Schulz@auma.com

Büro Kraftwerke
DE-79373 Müllheim
Tel +49 7631 809 1192
Klaus.Wilhelm@auma.com

Büro Bayern
DE-93356 Teugn/Niederbayern
Tel +49 9405 9410 24
Mathias.Jochum@auma.com

AUMA Armaturen- und Antriebstechnik GmbH
AT-2512 Tribuswinkel
Tel +43 2252 82540
office@auma.at
www.auma.at

AUMA (Schweiz) AG
CH-8965 Berikon
Tel +41 566 400945
RettichP.ch@auma.com

AUMA Servopohony spol. s.r.o.

CZ-10200 Praha 10
Tel +420 272 700056
auma-s@auma.cz
www.auma.cz

OY AUMATOR AB
FI-02270 Espoo
Tel +35 895 84022
auma@aumator.fi

AUMA France
FR-95157 Taverny Cédex
Tel +33 1 39327272
stephanie.vatin@auma.fr
www.auma.fr

AUMA ACTUATORS Ltd.
GB- Clevedon North Somerset BS21 6QH
Tel +44 1275 871141
mail@auma.co.uk
www.auma.co.uk

AUMA ITALIANA S.r.l. a socio unico
IT-20023 Cerro Maggiore (MI)
Tel +39 0331 51351
info@auma.it
www.auma.it

AUMA BENELUX B.V.
NL-2314 XT Leiden
Tel +31 71 581 40 40
office@benelux.auma.com
www.auma.nl

AUMA Polska Sp. z o.o.
PL-41-310 Dabrowa Górnicza
Tel +48 32 26156 68
R.Ludzien@auma.com.pl
www.auma.com.pl

OOO Priwody AUMA
RU-141400 Moscow region for mail: 124365 Moscow a/ya 11
Tel +7 495 221 64 28
aumarussia@auma.ru
www.auma.ru

ERICH'S ARMATUR AB
SE-20039 Malmö
Tel +46 40 311550
info@erichsarmatur.se
www.erichsarmatur.se

GRÖNBECH & SÖNNER A/S
DK-2450 København SV
Tel +45 33 26 63 00
GS@g-s.dk
www.g-s.dk

IBEROPLAN S.A.
ES-28027 Madrid
Tel +34 91 3717130
iberoplan@iberoplan.com

D. G. Bellos & Co. O.E.
GR-13671 Acharnai Athens
Tel +30 210 2409485
info@dgbellos.gr

SIGURD SØRUM A. S.
NO-1301 Sandvika
Tel +47 67572600
post@sigurd-sorum.no

INDUSTRIA
PT-2710-297 Sintra
Tel +351 2 1910 95 00
jpalhares@tyco-valves.com

MEGA Endüstri Kontrol Sistemleri Tic. Ltd. Sti.
TR-06460 Öveçler Ankara
Tel +90 312 472 62 70
megaendustri@megaendustri.com.tr

CTS Control Limited Liability Company
UA-02099 Kiyiv
Tel +38 044 566-9971, -8427
v_polyakov@cts.com.ua

Africa

AUMA South Africa (Pty) Ltd.
ZA-1560 Springs
Tel +27 11 3632880
aumasa@mweb.co.za

A.T.E.C.
EG- Cairo
Tel +20 2 3599680 - 3590861
atec@intouch.com

America

AUMA ACTUATORS INC.
US-PA 15317 Canonsburg
Tel +1 724-743-AUMA (2862)
mailbox@auma-usa.com
www.auma-usa.com

AUMA Chile Representative Office
CL- Buin
Tel +56 2 821 4108
aumachile@adsl.tie.cl

LOOP S. A.
AR-C1140ABP Buenos Aires
Tel +54 11 4307 2141
contacto@loopsa.com.ar

Asvotec Termoindustrial Ltda.
BR-13190-000 Monte Mor/ SP.
Tel +55 19 3879 8735
atuador.auma@asvotec.com.br

TROY-ONTOR Inc.
CA-L4N 5E9 Barrie Ontario
Tel +1 705 721-8246
troy-ontor@troy-ontor.ca

MAN Ferrostaal de Colombia Ltda.
CO- Bogotá D.C.
Tel +57 1 401 1300
dorian.hernandez@manferrostaal.com
www.manferrostaal.com

PROCONTIC Procesos y Control Automático
EC- Quito
Tel +593 2 292 0431
info@procontic.com.ec

IESS DE MEXICO S. A. de C. V.
MX-C.P. 02900 Mexico D.F.
Tel +52 55 55 561 701
informes@iess.com.mx

Corsusa S.A.C.
PE- Miraflores - Lima
Tel +51 1444-1200 / 0044 / 2321
corsusa@corsusa.com
www.corsusa.com

PASSCO Inc.
PR-00936-4153 San Juan
Tel +1 809 78 77 20 87 85
Passco@prtc.net

Suplibarca
VE- Maracaibo Estado, Zulia
Tel +58 261 7 555 667
suplibarca@intercable.net.ve

Asia

AUMA Actuators (Tianjin) Co., Ltd.
CN-300457 Tianjin
Tel +86 22 6625 1310
mailbox@auma-china.com
www.auma-china.com

AUMA (INDIA) PRIVATE LIMITED
IN-560 058 Bangalore
Tel +91 80 2839 4655
info@auma.co.in
www.auma.co.in

AUMA JAPAN Co., Ltd.

JP-210-0848 Kawasaki-ku, Kawasaki-shi Kanagawa
Tel +81 44 329 1061
mailbox@auma.co.jp

AUMA ACTUATORS (Singapore) Pte Ltd.
SG-569551 Singapore
Tel +65 6 4818750
sales@auma.com.sg
www.auma.com.sg

Al Ayman Industrial. Eqpts
AE- Dubai
Tel +971 4 3682720
auma@emirates.net.ae

PERFECT CONTROLS Ltd.
HK- Tsuen Wan, Kowloon
Tel +852 2493 7726
joeip@perfectcontrols.com.hk

DW Controls Co., Ltd.
KR-153-803 Seoul Korea
Tel +82 2 2113 1100
sichoi@actuatorbank.com
www.actuatorbank.com

AL-ARFAJ Eng. Company W. L. L.
KW-22004 Salmiyah
Tel +965 4817448
arfaj@qualitynet.net

Petrogulf W.L.L.
QA- Doha
Tel +974 4350 151
pgulf@qatar.net.qa

Sunny Valves and Intertrade Corp. Ltd.
TH-10120 Yannawa Bangkok
Tel +66 2 2400656
sunnyvalves@inet.co.th
www.sunnyvalves.co.th/

Top Advance Enterprises Ltd.
TW- Jhonghe City Taipei Hsien (235)
Tel +886 2 2225 1718
support@auma-taiwan.com.tw
www.auma-taiwan.com.tw

Australia

BARRON GJM Pty. Ltd.
AU-NSW 1570 Artarmon
Tel +61 294361088
info@barron.com.au
www.barron.com.au

auma® auma®

AUMA Riester GmbH & Co. KG
P.O. Box 1362
79373 Müllheim, Germany
Tel +49 7631 - 809-0
Fax +49 7631 - 809 1250
riester@auma.com
www.auma.com

AUMA Riester GmbH & Co. KG
P. O. Box 1151
D - 73747 Ostfildern
Tel +49 711 - 34803 0
Fax +49 711 - 34803 34
riester@wof.auma.com
www.auma.com



Certificate Registration No.
12 100/104 4269

For detailed information about AUMA products refer to the Internet:

www.auma.com

Y000.777/003/en/1.04